

# NXPTZ DELUX

FULL HD PTZ CAMERA FOR ONSHORE/OFFSHORE APPLICATIONS WITH NEW DELUX TECHNOLOGY, FOR DAY/NIGHT VIEWING WITH EXCEPTIONAL NIGHT BRIGHTNESS



IP66/IP67  
IP68/IP69

TYPE  
4X



delux  
technology



NXPTZ DELUX

NXPTZ DELUX



## DESCRIPTION

NXPTZ DELUX is a Full HD PTZ camera which integrates new imaging and encoding technology for outdoor video surveillance, allowing recordings to be produced with incredibly bright and vivid colours both by day and by night.

In addition to improved light sensitivity with outstanding colour reproduction and greater noise reduction, DELUX technology gives advanced new performance in terms of proportional zoom control and management of privacy masking for sensitive areas.

The Full HD PTZ camera is entirely manufactured in stainless steel AISI 316L and does not require maintenance. Resistance to corrosion is guaranteed and improved by a double surface polishing process and guarantees high performance for use in highly corrosive environments such as industrial and offshore/onshore marine environments.

NXPTZ DELUX integrates a Day/Night, Full HD camera, 1080p with a 30x optical zoom and a frame rate of 60fps. It is capable of accurately pinpoint details in any scene – even dynamic, rapidly changing situations.

The video images are sent via the network with compression H.264/AVC, MPEG4, MJPEG or JPEG and up to a maximum of 3 simultaneous and independent Full HD video streams.

An equally noteworthy point is that the IP66/IP67/IP68 ratings guarantee the complete protection against harsh weather and immersion in up to 1 metre of water for 2 hours. Moreover the IP69 rating allows the device to be cleaned with high pressure and high temperature water jets.

The NXPTZ series products are Lloyd's Register Type Approval System Test Specification Number 1 certified and therefore can be used in Marine and Offshore applications for environmental categories ENV1, ENV2, ENV3 and ENV5 (eg. passenger ships, open-air decks, closed spaces and technical areas that may be subject to heat generated by other equipment, docking procedures).

## CERTIFICATIONS



## MAIN FEATURES

Marine Certification: Lloyd's Register Marine Type Approval

In stainless steel AISI 316L, micro-shot peened in silicon and electro-polished  
Camera Full HD 1080p, 30x, 60fps

Minimum Illumination:

- Colour: 0.006lx
- B/W: 0.0006lx

Video compression H.264/AVC, MJPEG, JPEG and MPEG4

Complies with ONVIF, Profile Q, Profile S and Profile T

Day/Night (Auto ICR: automatic removal of IR filter)

De-fog function

Up to 3 simultaneous video streams in FULL HD

1 alarm input and 1 relay output

Variable speed: from 0.1°/s up to 100°/s Pan and Tilt

Position accuracy: 0.02°

Pre-wired multipolar cable

Integrated wiper

Protection degree: IP66, IP67, IP68, IP69

## TECHNICAL DATA

### MECHANICAL

AISI 316L stainless steel construction  
External surfaces micro-shot peened in silicon and electro-polished  
Dynamic positioning control system  
Zero backlash  
Pre-wired multipolar cable (3m or, on request, 10m)  
Horizontal rotation: 360°, continuous rotation  
Vertical rotation: from -90° up to +90°  
Horizontal speed (variable): from 0.1°/s up to 100°/s  
Tilt speed (variable): from 0.1°/s up to 100°/s  
Accuracy of preset positions: 0.02°  
Integrated wiper  
Unit weight: 22kg (44lb)

### ELECTRICAL

Supply voltage/Current consumption:

- 230Vac, 0.5A max, 50/60Hz
- 120Vac, 1A max, 50/60Hz
- 24Vac, 5A max, 50/60Hz

Power consumption:

- 120W max

### NETWORK

Ethernet connection: 100 Base-TX  
Connector: RJ45

### CYBERSECURITY

Digitally signed firmware  
Password restricted access (HTTP digest)  
Support of various user access levels  
Control of accesses IEEE 802.1X  
HTTPS cryptography using TLS1.0, TLS1.1, TLS1.2 and TLS1.3  
Centralised certificate management  
Complies with ONVIF Security Service specifications

### VIDEO

Video encoder

- Communication protocol: ONVIF, Profile Q, Profile S and Profile T
- Device configuration: TCP/IPv4-IPv6, UDP/IPv4-IPv6, HTTP, HTTPS, NTP, DHCP, WS-DISCOVERY, DSCP, IGMP (Multicast), SOAP, DNS
- Streaming: RTSP, RTCP, RTP/IPv4-IPv6, HTTP, Multicast
- Video compression: H.264/AVC, MJPEG, JPEG, MPEG4
- 3 independent video streams Full HD
- Image resolution: from 320x180pixel up to 1920x1080pixel in 6 steps
- Selectable frame rate from 1 to 60 images per second (fps)
- Web Server
- Directional OSD (maximum 4 settable areas)
- Motion Detection
- QoS: Differentiated DSCPs for streaming and device management
- SNMP and NTCIP protocols

### I/O INTERFACE

I/O alarm board:

- Alarm inputs: 1
- Relay outputs: 1 (1A, 30Vac/60Vdc max)

### CAMERAS

#### Day/Night Full HD 30x DeLux

Resolution: Full HD 1080p (1920x1080pixel)  
Image Device: 1/2.8" Exmor™ R CMOS sensor  
Effective Pixels: approx. 2.38 Megapixels  
Minimum Illumination:

- Colour: 0.006lx (F1.6, 30 IRE)
- B/W: 0.0006lx (F1.6, 30 IRE)

Focal length: from 4.5mm (wide) up to 135mm (tele)  
Zoom: 30x (480x with digital zoom)  
Iris: from F1.6 up to F9.6 (Auto, Manual)  
Horizontal Viewing Angle: from 61.6° (wide end) up to 2.50° (tele end)  
Vertical Viewing Angle: from 37.07° (wide end) up to 1.44° (tele end)  
Shutter speed: from 1/1s up to 1/10000s (Auto, Manual)  
White balance: Auto, Manual  
Gain: from 0dB up to 36dB (Auto, Manual)  
Wide Dynamic Range: 120dB  
Focus System: Auto, Manual, Trigger  
Picture Effects: E-flip, Color enhancement  
Noise removal: 2D (3 levels), 3D (3 levels)  
Exposure Control: Auto, Manual, Priority (Iris Priority, Shutter Priority), Brightness, Custom  
De-fog: On/Off  
Privacy zones masking (maximum 8 settable masks)

### ENVIRONMENT

For indoors and outdoors installation  
Operating temperature: from -40°C (-40°F) up to +60°C (140°F) (continuous)  
Absolute maximum temperature: +70°C (158°F) (intermittent)  
Relative humidity: from 5% up to 95%

### CERTIFICATIONS

Electrical safety (CE): EN60950-1, IEC60950-1  
Electromagnetic compatibility (CE): EN61000-6-4, EN61000-3-2, EN61000-3-3, EN50130-4, EN55032 (Class A)  
Outdoor installation (CE): EN60950-22, ICE60950-22  
IP protection degree (EN60529): IP66, IP67, IP68, IP69  
EAC certification  
UL certification (UL60950-1, CAN/CSA C22.2 No. 60950-1-07): cULus Listed (only for 24Vac version)  
Electromagnetic compatibility (North America): FCC part 15 (Class A), ICES-003 (Class A)  
Level of protection Type (UL50E): 4X (only for 24Vac version)

### CERTIFICATIONS - MARINE APPLICATIONS

Lloyd's Register Marine Type Approval certification (the 24Vac versions require a filter accessory FM1010):

- Test Specification Number 1 (ENV1, ENV2, ENV3, ENV5)

Electromagnetic compatibility: EN60945  
Salty fog resistance: EN60068-2-52  
Tested at 70°C (158°F) for 16 hours in compliance with EN60068-2-2

**ACCESSORIES**

WASPT0V5L5M00	Water tank 5l (1.3gal), pump with delivery up to 5m (16ft), IN 230Vac-24Vac-120Vac
WASPT0V23L5M00	Water tank 23l (6gal), pump with delivery up to 5m (16ft), IN 230Vac-24Vac-120Vac
WASPT0V23L11M00	Water tank 23l (6gal), pump with delivery up to 11m (36ft) with water floating, IN 230Vac-24Vac-120Vac
WASPT1V23L30M00	Water tank 23l (6gal), pump with delivery up to 30m (98ft) with water floating, IN 230Vac
WASPT3V23L30M00	Water tank 23l (6gal), pump with delivery up to 30m (98ft) with water floating, IN 120Vac
WASN1V10L20M00	Tank 10l (2.6gal) with integrated manual pump controlled by solenoid valve, delivery head up to 20m (66ft) max, IN 230Vac
WASN2V10L20M00	Tank 10l (2.6gal) with integrated manual pump controlled by solenoid valve, delivery head up to 20m (66ft) max, IN 24Vac
WASN3V10L20M00	Tank 10l (2.6gal) with integrated manual pump controlled by solenoid valve, delivery head up to 20m (66ft) max, IN 120Vac
FM1010	EMC filter for Marine certification

**BRACKETS AND ADAPTORS**

NXPTZWB	AISI 316L stainless steel wall bracket
NXPTZTW	AISI 316L stainless steel parapet or ceiling mounting bracket
NXPTZCOL	AISI 316L stainless steel pole adapter module
NXPTZCW	AISI 316L stainless steel corner adapter module

**PACKAGE**

Model Number	Weight	Dimensions (WxHxL)	Master carton
NXPTZHD11VW0Z00B	26.5kg (58lb)	54x31x49cm (21x12x19in)	-

**NXPTZ DELUX - CONFIGURATION OPTIONS**

	Voltage					Video Output						
<b>NXPTZHD</b>	<b>1</b>	230Vac	<b>1</b>	Videotec super low-light Day/Night 30X zoom, Full HD camera	<b>V</b>	With alarm board	<b>W</b>	With wiper	<b>0</b>	<b>Z</b>	IP H.264/AVC control, ONVIF protocol Profile Q, Profile S and Profile T	<b>00B</b>
	<b>2</b>	24Vac										
	<b>3</b>	120Vac										

# TECHNICAL DRAWINGS

The indicated measurements are expressed in millimetres.

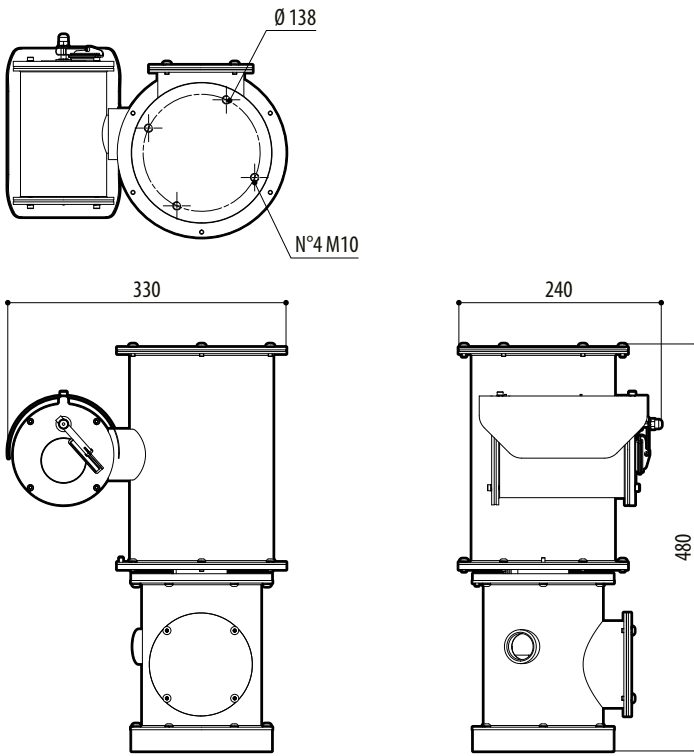

NXPTZ DELUX